

# HIGH PERFORMING G55 SERIES CO<sub>2</sub> OPERATED BAG-IN-BOX PUMP



## The Flojet Model G55 Series Pump

- Supplies Bag-In-Box post mix soft drink and juice syrups to all standard and fast flow valves.
- Features quick-disconnect ports reducing total service and installation time.
- Compact design with performance and reliability.
- Service life over 100,000 gallons (378,500 L).

**FLOJET**



## TYPICAL INSTALLATION

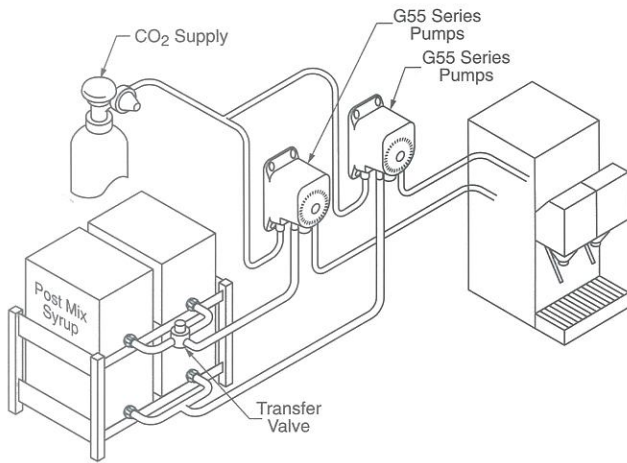

## APPLICATIONS

- Designed for dispensing Bag-in-Box syrups, juice concentrate (without pulp or particulate), teas, wines, draft beer and liquor.
  - Supplies the following from remote location:
    - eight (8) 3.0 oz. valves<sup>1</sup> or
    - four (4) 4.5 oz. valves<sup>2</sup>
- <sup>1</sup>Each valve dispenses syrup at 0.5 oz./sec.  
<sup>2</sup>Each valve dispenses syrup at 0.75 oz./sec.

## SPECIAL FEATURES

- Highest flow rate available.
- Capable of CO<sub>2</sub> inlet pressures up to 90 psi (6.2 bar).
- Ultimate performance and reliability with extended service life.
- Built-in auto shutoff, automatically shuts off pump when bag is empty and restarts when a full bag is connected.
- Quiet operation with exhaust muffler.
- Easy installation with all quick disconnect ports.
- High CO<sub>2</sub> inlet supply capability, exceeds FCB machine requirements.
- Service life over 100,000 gallons (378,500 L).

## SPECIFICATIONS

<b>Pump Design</b>	Positive Displacement, Double Diaphragm
<b>Power Source</b>	CO <sub>2</sub> Gas, Nitrogen or Compressed Dry Filtered Air
<b>Materials of Construction (wetted parts)</b>	Polypropylene, Santoprene®, EPDM, AISI 303 & 304 Stainless Steel
<b>Temperature Limits</b>	34° - 120° F (1.1° - 49° C)
<b>Weight</b>	1.24 lbs. (0.56 kg.)
<b>Dimensions</b>	5.27" H x 3.21" W x 4.58" D (133.8 mm x 81.5 mm x 116.3 mm)
<b>Displacement</b>	3.2 oz. per cycle
<b>Self Priming</b>	Up to 10 ft. (3.05 m)
<b>Operating Pressure</b>	20 psi (1.4 bar) min. / 90 psi (6.2 bar) max.
<b>Liquid Inlet Pressure</b>	30 psi (2.1 bar) max.
<b>Flow Rate</b>	7.0 oz. (207.0 ml)/sec. - Open Flow
<b>Approvals</b>	NSF listed, S-K & CE

## PUMP PERFORMANCE

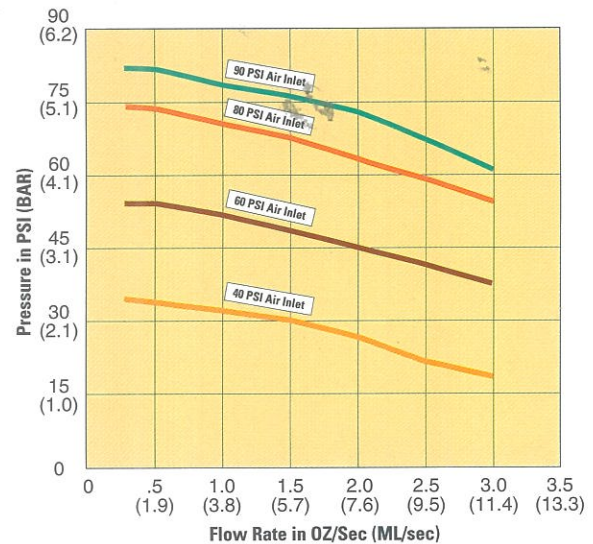

## DIMENSIONS inches (mm)

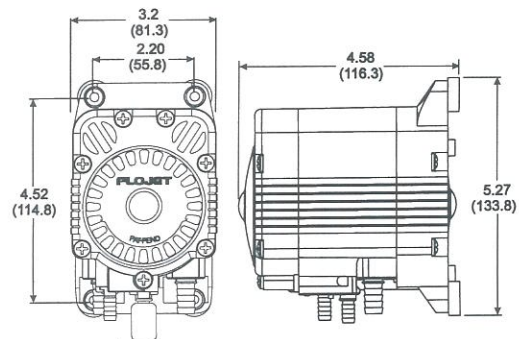

Flojet



www.flojet.com e-mail: sales@flojet.com

For further information, contact your FLOJET representative, or write to:

**FLOJET**  
 20 Icon • Foothill Ranch, CA 92610  
 Tel: 949-859-4945  
 1-800-2 FLOJET  
 Fax: 1-949-859-1153

ISO 9001 Certified

**FLOJET (EUROPE) LTD.**  
 Unit 1, Avant Business Centre  
 Denbigh West Industrial Estate  
 Milton Keynes, Bucks, England MK1 1DL  
 Tel: 44-1908-370088 • Fax: 44-1908-373731

F100-171 Rev 3/02-5M