

43 Series Carbonator in a Box



Standard Features

- Durable rotary-vane brass water pump delivers atomized water to the carbonator tank. Includes internal 100 micron strainer and pressure relief valve.
- Diamond Brite stainless steel construction resists corrosion and is easily cleaned.
- Exclusive two-piece probe design reduces service time, improves diagnostics, and lowers costs. No need to shut off CO2 or water during service.
- Fully-encapsulated electronics package is easily removed for testing and service without the need to depressurize the tank.
- Specially designed probe electronics resists damage from amperage spikes for greater reliability.
- Liquid-level float assembly and heat sink probe cap ensure trouble-free operation and extend service life.
- Textured painted steel cabinet protects carbonator components from damage.
- Vibration-isolating rubber feet provide sound insulation.
- Anderson Brass ASSE 1022-specified backflow prevention device included.
- 5-year warranty on carbonator tank and liquid level control.
- Certified by NSF and UL. Lead content certified for compliance with California AB-1953 & Vermont Act 193.



Specifications

| 43 Series Carbonator in a Box | |
|--------------------------------------|--|
| Water Capacity | 100 gph (378 lph) maximum |
| Tank Capacity | 32 fl. ounces (0.95 liter) |
| Soda Outlets | 1 |
| Base | Black textured painted steel cabinet with rubber vibration-isolating feet. Can be wall mounted |
| Electrical | 115V / 60 hz / 1ph and 220V / 50-60 hz / 1 ph |
| Pump | 100 GPH rotary-vane brass pump with internal strainer and by-pass relief |
| Pressure Relief | 180 PSI pressure relief valve |
| Backflow Protection | Anderson Brass ASSE 1022-specified backflow prevention device |
| Motor | 115V models: 1/3 HP, 6.5 amps, 1725 RPM and 220V models: 1/4 HP, 2.0 amps, 1425 RPM |
| Inlet/Outlet Fittings | 1/4 male flare CO2 inlet, 3/8 male flare water inlet, 3/8 male flare soda water outlet |
| Approximate Shipping Weights | 29 lbs. (13.2 kg) |
| Carton Dimensions | 15 x 15 x 15 in. (38 x 38 x 38 cm) |

| Model Number | Description | Model Number | Description |
|--------------|---|--------------|--|
| 43-5502 | McCann's Carbonator in a Box, 115V 60hz, 32-Ounce SS tank | 43-5602 | McCann's Carbonator in a Box, 220V 50/60hz, 32-Ounce SS tank |

| Accessories | Description |
|-------------|--|
| 16-0856 | Optional Pump Saver – Automatically shuts carbonator motor off if water pressure drops below 15 PSI. Restarts unit when incoming water pressure returns to 20 PSI or more. |
| 16-1459 | Optional 6" Stand |
| 16-1480 | Optional Wall-Mounted Shelf – For 43 Series, E200, and E400 models |

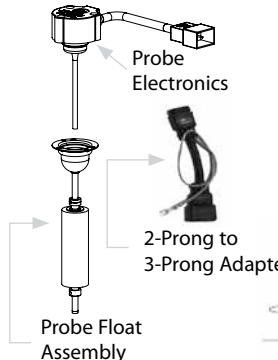

Easy to test 2-Piece Probe

1. Remove probe.
2. Pass magnetic tip of screwdriver across lower end of the tube extending from electronics package.
3. If reed switch closes, motor should start.

Carbonator in a Box

- A 6.5" (16.5 cm)
- B 12.5" (31.8 cm)
- C 15.0" (38.1 cm)

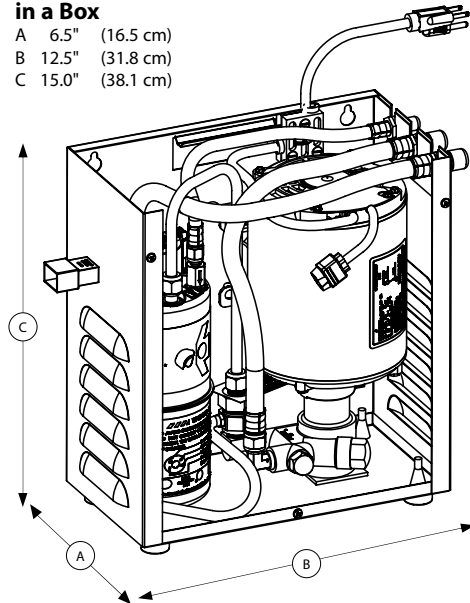

4774 ©2017 McCann's 1/11 Continuing product improvement may necessitate change of specifications without notice.